



VVF42..
VVF42..K



VXF42..

ACVATIX™

2- and 3-port valves with flanged connections, PN 16

**VVF42..
VVF42..K
VXF42..**

From the large-stroke valve line

-
- Performance valves for medium temperatures from -10...150 °C
 - Valve body of grey cast iron EN-GJL-250
 - DN 15...150
 - k_{vs} 1.6...400 m³/h
 - Flange type 21, flange design B
 - VVF42..K with pressure compensation to handle high differential pressure
 - Equipable with electro-motoric actuators SAX.., SAV.. or electro-hydraulic actuators SKD.., SKB.., SKC..

Use

In boiler, district heating and refrigeration plants, cooling towers, heating groups, in ventilation and air-handling units as control or shutoff valves.

For use in closed hydraulic circuits (observe cavitation).

Type summary

Valves	Actuators Stroke Positioning force Data sheet				SAX.. ¹⁾		SKD..		SKB..		SAV.. ¹⁾		SKC..						
					20 mm				40 mm										
PN 16					800 N		1000 N		2800 N		1600 N		2800 N						
					N4501		N4561		N4564		N4503		N4566						
-10...150 °C	Stock number	DN	k _{vs} [m ³ /h]	S _V	Δp _s	Δp _{max}	Δp _s	Δp _{max}	Δp _s	Δp _{max}	Δp _s	Δp _{max}	Δp _s	Δp _{max}					
					[kPa]														
VVF42.15-1.6	S55204-V100	15	1.6	> 50	1600	400	1600	400	1600	400	-	-	-	-					
VVF42.15-2.5	S55204-V101	15	2.5																
VVF42.15-4	S55204-V102	15	4																
VVF42.20-6.3	S55204-V103	20	6.3																
VVF42.25-6.3	S55204-V104	25	6.3																
VVF42.25-10	S55204-V105	25	10																
VVF42.32-16	S55204-V106	32	16								900	1200							
VVF42.40-16	S55204-V107	40	16								550	750	1200	400	1250	-	-		
VVF42.40-25	S55204-V108	40	25																
VVF42.50-31.5	S55204-V109	50	31.5								> 100	350	300	450	1200	700	750	400	-
VVF42.50-40	S55204-V110	50	40																
VVF42.65-50	S55204-V111	65	50																
VVF42.65-63	S55204-V112	65	63																
VVF42.80-80	S55204-V113	80	80																
VVF42.80-100 ²⁾	S55204-V114	80	100	125	75	175	125	450	250	225							-	-	
VVF42.100-125	S55204-V115	100	125																
VVF42.100-160 ²⁾	S55204-V116	100	160	-	-	-	-	-	-	160							125	300	250
VVF42.125-200	S55204-V117	125	200																
VVF42.125-250	S55204-V118	125	250																
VVF42.150-315	S55204-V119	150	315																
VVF42.150-400 ²⁾	S55204-V120	150	400	80	60	125	100	-	-	-	-								
-5...150 °C																			
VVF42.50-40K ³⁾	S55204-V121	50	40	> 100	1600	400	1600	400	1600	400	-	-	-	-					
VVF42.65-63K ³⁾	S55204-V122	65	63																
VVF42.80-100K ³⁾	S55204-V123	80	100																
VVF42.100-160K ³⁾	S55204-V124	100	160								-	-	-	-	1600	400	1600	400	
VVF42.125-250K ³⁾	S55204-V125	125	250								-	-	-	-	1400	-	-	-	
VVF42.150-360K	S55204-V126	150	360																

¹⁾ Suitable for medium temperatures up to 130 °C; SAV.. available in select countries only

²⁾ Valve characteristic for k_{vs} value 100 m³/h from 70% stroke, k_{vs} value 160 m³/h from 85% stroke and k_{vs} value 400 m³/h from 90% stroke is optimized for maximum volumetric flow

³⁾ Valve characteristics for pressure compensated valves for k_{vs} value 100 m³/h from 70% stroke, k_{vs} value 40,160 and 250 m³/h from 80% stroke and k_{vs} value 63 m³/h from 90% stroke is optimized for maximum volumetric flow.

Valves	Actuators				SAX.. ¹⁾	SKD..	SKB..	SAV.. ¹⁾	SKC..											
	Stroke				20 mm			40 mm												
PN 16	Positioning force				800 N	1000 N	2800 N	1600 N	2800 N											
	Data sheet				N4501	N4561	N4564	N4503	N4566											
	Stock number	DN	k _{vs} [m ³ /h]	S _v	Δp_{max} [kPa]															
					A→B B	AB→A B	A→B B	AB→A B	A→B B	AB→A B	A→B B	AB→A B	A→A B	AB→A B						
-10...150 °C																				
VXF42.15-1.6	S55204-V127	15	1.6	> 50	400	100	400	100	400	100	-	-	-	-	-	-	-	-	-	-
VXF42.15-2.5	S55204-V128	15	2.5																	
VXF42.15-4	S55204-V129	15	4																	
VXF42.20-6.3	S55204-V130	20	6.3																	
VXF42.25-6.3	S55204-V131	25	6.3																	
VXF42.25-10	S55204-V132	25	10																	
VXF42.32-16	S55204-V133	32	16	> 100	300	50	200	80	400	100	-	-	-	-	-	-	-	-	-	-
VXF42.40-16	S55204-V134	40	16																	
VXF42.40-25	S55204-V135	40	25																	
VXF42.50-31.5	S55204-V136	50	31.5																	
VXF42.50-40	S55204-V137	50	40																	
VXF42.65-50	S55204-V138	65	50																	
VXF42.65-63	S55204-V139	65	63																	
VXF42.80-80	S55204-V140	80	80																	
VXF42.80-100 ²⁾	S55204-V141	80	100																	
VXF42.100-125	S55204-V142	100	125																	
VXF42.100-160 ²⁾	S55204-V143	100	160																	
VXF42.125-200	S55204-V144	125	200																	
VXF42.125-250	S55204-V145	125	250																	
VXF42.150-315	S55204-V146	150	315																	
VXF42.150-400 ²⁾	S55204-V147	150	400																	

1) Suitable for medium temperatures up to 130 °C; SAV.. available in select countries only

2) Valve characteristic for k_{vs} value 100 m³/h from 70% stroke, k_{vs} value 160 m³/h from 85% stroke and k_{vs} value 400 m³/h from 90% stroke is optimized for maximum volumetric flow

DN = Nominal size

k_{vs} = Flow nominal value of cold water (5...30 °C) through the fully opened valve (H₁₀₀) at a differential pressure of 100 kPa (1 bar)

S_v = Rangeability

Δp_s = Maximum permissible differential pressure at which the motorized valve still closes securely against the pressure

Δp_{max} = Maximum permissible differential pressure across the valve's throughport for the entire positioning range of the motorized valve

Ordering

Example

Product number	Stock number	Description
VXF42.65-63	S55204-V139	3-port valve with flange, PN 16
SKD32.50	SKD32.50	Electro-hydraulic actuator

Delivery

Valves, actuators and accessories are packed and delivered as separate items.

Note

Counter-flanges, bolts and gaskets must be provided on site.

Spare parts, Rev.-No.

See page 13

Equipment combinations

Product number	Description	Stroke	Positioning force	Operating voltage	Positioning signal	Spring return time	Positioning time	LED	Manual adjuster	Auxiliary functions										
SAX31.00	S55150-A105	20 mm	800 N	AC 230 V	3-position	-	120 s	-	Press and fix	1)										
SAX31.03	S55150-A106			AC 24 V DC 24 V	0...10 V 4...20 mA 0...1000 Ω	-	30 s	✓		-	-	2), 3)								
SAX61.03 SAX61.03U	S55150-A100 S55150-A100-A100																			
SAX81.00	S55150-A102			3-position	-	120 s	-	-		-	-	1)								
SAX81.03 SAX81.03U	S55150-A103 S55150-A103-A100												30 s							
SKD32.21	SKD32.21			20 mm	1000 N	AC 230 V	3-position	8 s		Opening: 30 s Closing: 10 s	-	Turn, Position is maintained	1)							
SKD32.50	SKD32.50	-	120 s					-	-											
SKD32.51	SKD32.51	8 s																		
SKD60	SKD60	AC 24 V	0...10 V 4...20 mA 0...1000 Ω			-	15 s			Opening: 30 s Closing: 15 s	✓	-	2)							
SKD62 SKD62U	SKD62 SKD62U																			
SKD62UA	SKD62UA																			
SKD82.50 SKD82.50U	SKD82.50 SKD82.50U							3-position	-					120 s	-	-	-	1)		
SKD82.51 SKD82.51U	SKD82.51 SKD82.51U																			
SKB32.50	SKB32.50							20 mm	2800 N					AC 230 V	3-position	-	120 s	-	Turn, Position is maintained	1)
SKB32.51	SKB32.51															10 s				
SKB60	SKB60	-																		
SKB62 SKB62U	SKB62 SKB62U	AC 24 V	0...10 V 4...20 mA 0...1000 Ω	-	10 s	Opening: 120 s Closing: 10 s	✓			-	2)									
SKB62UA	SKB62UA																			
SKB82.50 SKB82.50U	SKB82.50 SKB82.50U	3-position	-	120 s	-	-	-			-	1)									
SKB82.51 SKB82.51U	SKB82.51 SKB82.51U																			
SAV31.00	S55150-A112	40 mm	1600 N	AC 230 V	3-position	-	120 s			-	Press and fix	1), 5)								
SAV61.00 SAV61.00U	S55150-A110 S55150-A110-A100			AC 24 V DC 24 V	0...10 V 4...20 mA 0...1000 Ω			-	-	✓		-	-	1), 2), 5), 6)						
SAV81.00 SAV81.00U	S55150-A111 S55150-A111-A100														3-position					
SKC32.60	SKC32.60	40 mm	2800 N	AC 230 V	3-position	-	120 s	-	Turn, Position is maintained	1)										
SKC32.61	SKC32.61					18 s														
SKC60	SKC60					-														
SKC62 SKC62U	SKC62 SKC62U			AC 24 V	0...10 V 4...20 mA 0...1000 Ω	-	20 s	Opening: 120 s Closing: 20 s	✓	-	2)									
SKC62UA	SKC62UA																			
SKC82.60 SKC82.60U	SKC82.60 SKC82.60U			3-position	-	120 s	-	-	-	-	1)									
SKC82.61 SKC82.61U	SKC82.61 SKC82.61U																			

- 1) Auxiliary switch, potentiometer
- 2) Position feedback, forced control, selection of valve characteristic
- 3) Optional: sequence control, selection of acting direction
- 4) Plus sequence control, stroke limitation, and selection of acting direction
- 5) Stem heating element (optional)
- 6) Function module (optional)

Product documentation

- Mounting Instructions M4030 74 319 0749 0
- Basic documentation P4030 Contains background information and technical basic knowledge of valves

Technical and mechanical design

The illustrations below show the basic design of the valves. Constructional features, such as the shape of plugs, may differ.

2-port valves

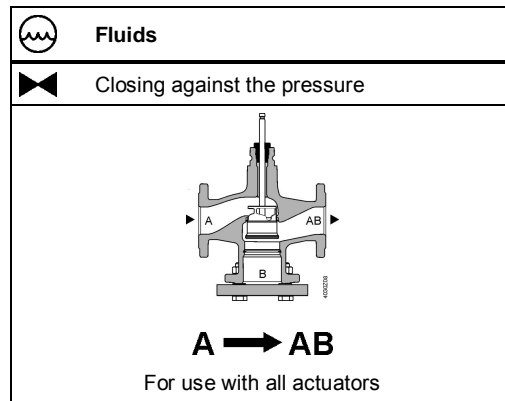

2-port valves pressure compensated

The VVF42..K valves use a pressure-compensated plug. This enables the same type of actuators to be used for the control of volumetric flow at higher differential pressures.

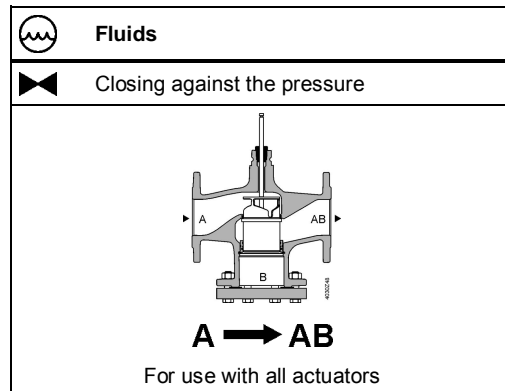

Note

2-port valves do not become 3-port valves by removing the blank flange!

3-port valves

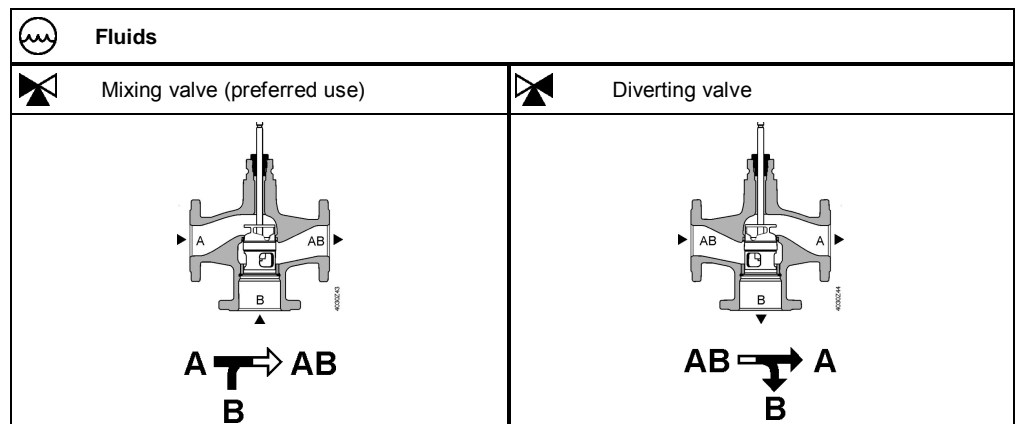

Accessories

Product number	Stock number	Description	Note	Example
ASZ6.6	S55845-Z108	Stem heating element	Required for medium temperatures < 0 °C	

Sizing

Flow chart

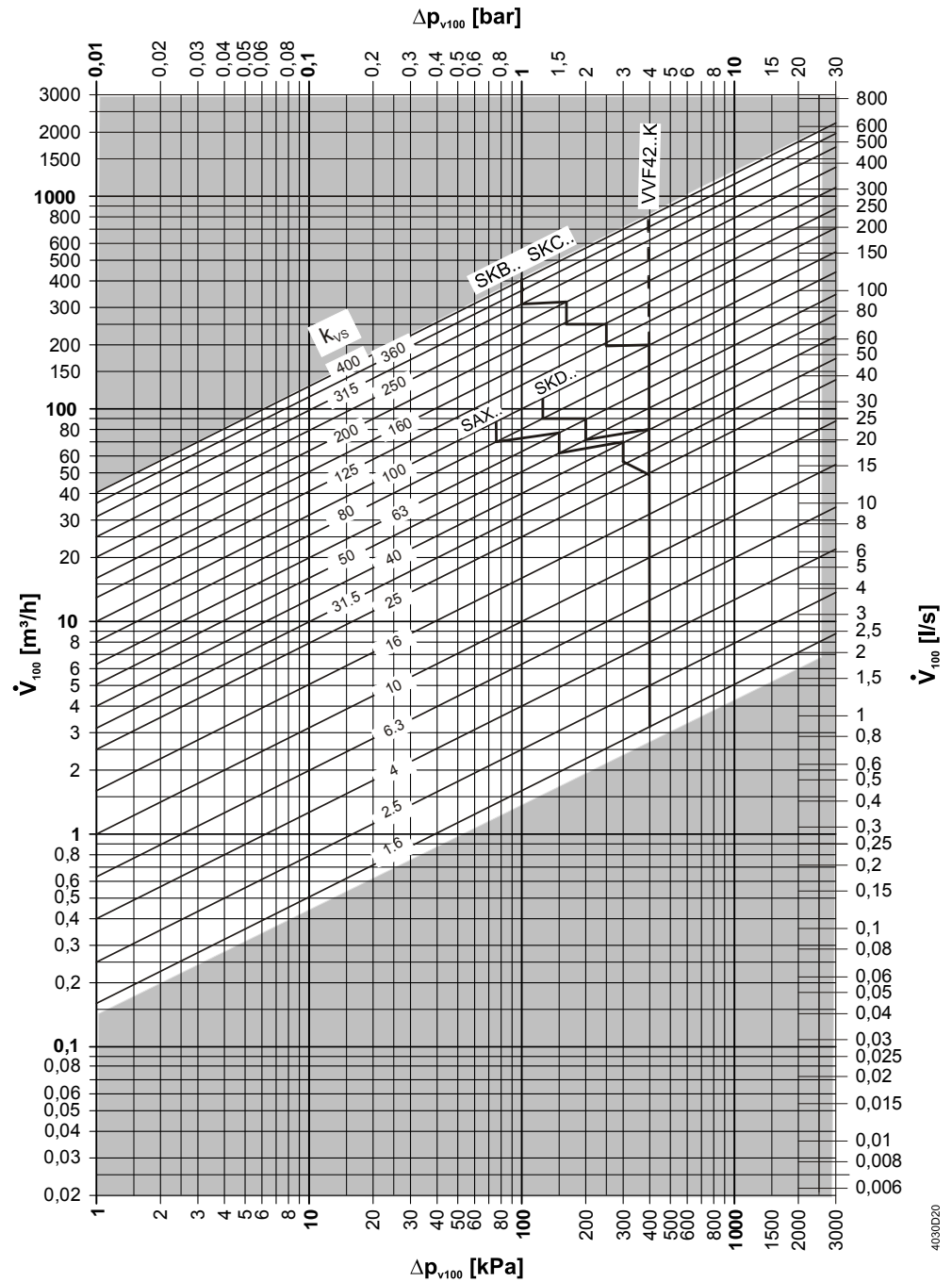

Δp_{max} values apply for the mixing function. Δp_{max} values for the diverting function see table „Type summary“, page 2

Valve characteristics
2-port valves

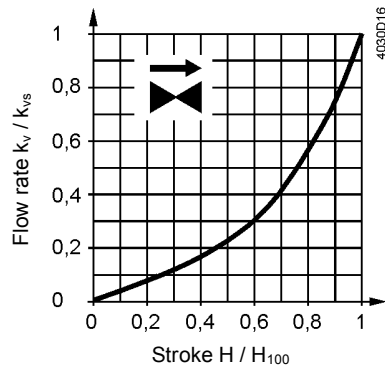

0...30%: Linear
30...100%: Equal percentage
 $n_{gl} = 3$ to VDI / VDE 2173
For high k_{vs} values the valve characteristic is optimized for maximum volumetric flow k_{V100} .

For product lines:
VVF42.125-250
VVF42.125-250K
VVF42.150-400
VVF42.150-360K

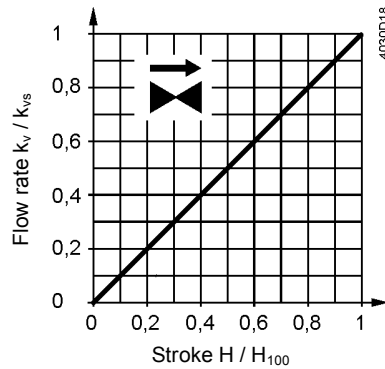

0...100%: Linear

3-port valves

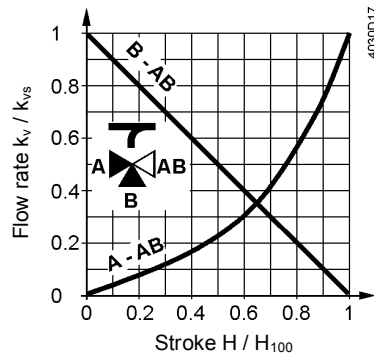

Throughport A-AB

0...30%: Linear
30...100%: Equal percentage
 $n_{gl} = 3$ to VDI / VDE 2173

For high k_{vs} values the valve characteristic is optimized for maximum volumetric flow k_{V100} .

Bypass B-AB

0...100%: Linear
Tor AB = constant flow
Tor A = variable flow
Tor B = bypass (variable flow)

Mixing: Flow from port A and port B to port AB
Diverting: Flow from port AB to port A and port B

For product lines:
VXF42.125-250
VXF42.150-400

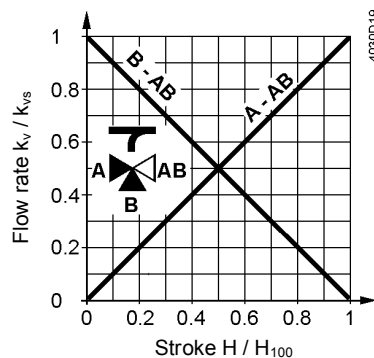

Throughport A-AB

0...100%: Linear

Bypass B-AB

0...100%: Linear

Operating pressure and medium temperature

Fluids, PN16 with V..F42..

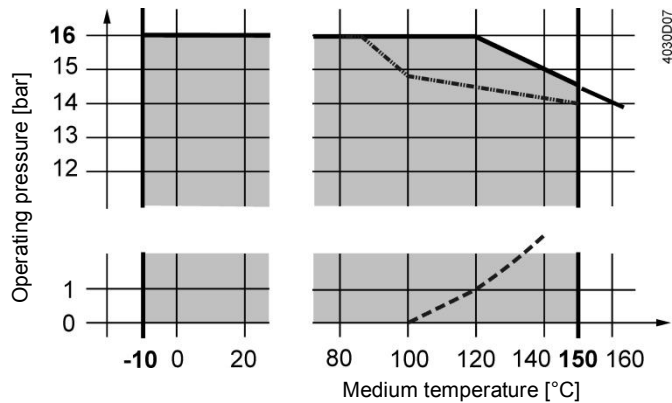

- Curve for saturated steam; steam forms below this line
- - - Operating pressure according to EN 1092, valid for 2-port valves with blank flange

Operating pressure and operating temperatures according to ISO 7005, EN 1092 and EN 12284

Notes

All relevant local directives must be observed

Medium compatibility and temperature ranges

Medium	Temperature range		Valve			Note
	T _{min} [°C]	T _{max} [°C]	VVF42..	VVF42..K	VXF42..	
Cold water	1	25	■	■	■	-
Low-temperature hot water	1	130	■	■	■	-
High-temperature hot water ¹⁾	130	150	■	■	■	-
	150	180	-	-	-	-
Water with antifreeze	-5	150	■	■	■	For medium temperatures below 0 °C, the stem heating ASZ6.6 has to be installed.
	-10	150	■	- ³⁾	■	
	-20	150	-	-	-	
Cooling water ²⁾	1	25	-	-	-	-
Brines	-5	150	■	■	■	For medium temperatures below 0 °C, the stem heating ASZ6.6 has to be installed.
	-10	150	■	- ³⁾	■	
	-20	150	-	-	-	
Super-clean water (demineralized and deionized water)	1	150	-	-	-	
Demineralized water according to VDI2035 / SWKI_BT102-01	1	150	■	■	■	

- ¹⁾ Differentiation due to saturated steam curve
- ²⁾ Open circuits
- ³⁾ VVF42..K can't be used with media below -5 °C due to the compensation sealing material

Fields of use

Fields of use		Valves		
		VVF42..	VVF42..K	VXF42..
Generation	Boiler plants	■	■	■
	District heating plants	■	■	-
	Refrigeration plants	■	■	■
Distribution	Heating groups	■	■	■
	Ventilation and air-handling units	■	■	■

Engineering notes

Mounting location	Preferably mount the valves at the return, as the temperature is lower there and the strain on the stem sealing gland is lower.
Dirt trap	Mount a dirt filter or dirt trap before the valve to ensure proper functioning, and a long service life of the valve. Remove dirt, welding beads, etc. from the valves and pipes.
Cavitation	Cavitation can be avoided by limiting the pressure differential across the valve depending on the medium temperature and prepressure.

Mounting notes

Monting position	Indoors	Outdoors

Mounting positions apply to both 2- and 3-port valves.

Commissioning notes



The valve may be put into operation only if actuator and valve are correctly assembled.

Note Ensure that actuator stem and valve stem are rigidly connected in all positions.

Function check

Valve	Throughport A→AB	Bypass B→AB
Valve stem extends	Closes	Opens
Valve stem retracts	Opens	Closes

Maintenance notes

Valves are equipped with maintenance-free, continuously lubricated stem sealing glands. See page 13 for replacement stem sealing glands.



When servicing valves or actuators:

- Deactivate the pump and turn off the power supply
- Close the shutoff valves
- Fully reduce the pressure in the piping system and allow pipes to completely cool down

If necessary, disconnect the electrical wires.

Disposal

Do not dispose of the device as household waste.

- Special handling of individual components may be mandated by law or make ecological sense.
- Observe all local and currently applicable laws and regulations.

Warranty

Application-related technical data are guaranteed only when the valves are used in connection with the Siemens actuators listed under "Equipment combinations", page 4.

When used with actuators of other manufacture, any warranty by Siemens becomes void.

Technical data

Functional data	PN class	PN 16	
	Connection	Flange	
	Operating pressure	See Section "Operating pressure and medium temperatures", page 8	
	Valve characteristics ¹⁾	See section "Valve characteristics", page 7	
	Leakage rate	Throughport	0...0.02% of k_{vs} value
		Bypass	0.5...2% of k_{vs} value ($k_{vs} \geq 6.3$) 0.5...3% of k_{vs} value ($k_{vs} 1.6; 2.5; 4$)
	Permissible media	See table "Medium compatibility and temperature ranges", page 8	
	Medium temperature		-10...150 °C
		VVF42..K:	-5...150 °C
	Rangeability	To DN 25: > 50 From DN 32: >100	
Nominal stroke	To DN 80: 20 mm From DN 100: 40 mm		
Materials	Valve body	EN-GJL-250	
	Blank flange	VVF.. S235JRG2	
	Valve stem	Stainless steel	
	Seat	Machined	
	Plug	Brass/ Bronze	
	Stem sealing gland	Brass EPDM O-rings PTFE sleeve silicon-free	
	Compensation sealing	Stainless steel FEPM (silicone-free)	
Standards, directives and approvals	Pressure Equipment Directive	PED 2014/68/EU	
	Pressure-carrying accessories	Scope: Article 1, section 1 Definitions: Article 2, section 5	
	Fluid group 2		PN 16
		≤DN 50	Without CE certification as per article 4, section 3 (sound engineering practice) ²⁾
		DN 65...125	Category I, Modul A, with CE-marking as per article 14, section 2
	DN 150	Category II, Modul A2, with CE-marking as per article 14, section 2, notified body number 0036	
EU conformity (CE)	DN 65...150	A5W00006523 ³⁾	

PN class	ISO 7268	
Operating pressure	ISO 7005, DIN EN 12284	
Flanges	ISO 7005	
Length of flanged valves	DIN EN 558-1, line 1	
Valve characteristic	VDI 2173	
Leakage rate	Throughport, bypass according to EN 60534-4 / EN 1349	
Water treatment	VDI 2035	
Environmental conditions		
Storage: IEC 60721-3-1	Class	1K3
	Temperature	-15...+55 °C
	Rel. humidity	5...95% r.h.
Transport: IEC 60721-3-2	Class	2K3, 2M2
	Temperature	-30...+65 °C
	Rel. humidity	< 95% r.h.
Operation: IEC 60721-3-3	Class	3K5, 3Z11
	Temperature	-15...+55 °C
	Rel. humidity	5...95% r.h.

Environmental compatibility

The product environmental declaration CE1E4403en01 ³⁾, CE1E4403en02 ³⁾ and CE1E4403en03 ³⁾ contains data on environmentally compatible product design and assessments (RoHS compliance, materials composition, packaging, environmental benefit, disposal).

Dimensions / Weight

Dimensions	See „Dimensions“, page 12
Weight	See „Dimensions“, page 12

- ¹⁾ For certain valve lines and high k_{vs} values, the valve characteristic is optimized for maximum volumetric flow k_{V100} .
- ²⁾ Valves where $PS \times DN < 1000$, do not require special testing and cannot carry the CE label.
- ³⁾ The documents can be downloaded from <http://siemens.com/bt/download>

Dimensions

VVF42.. VVF42..K

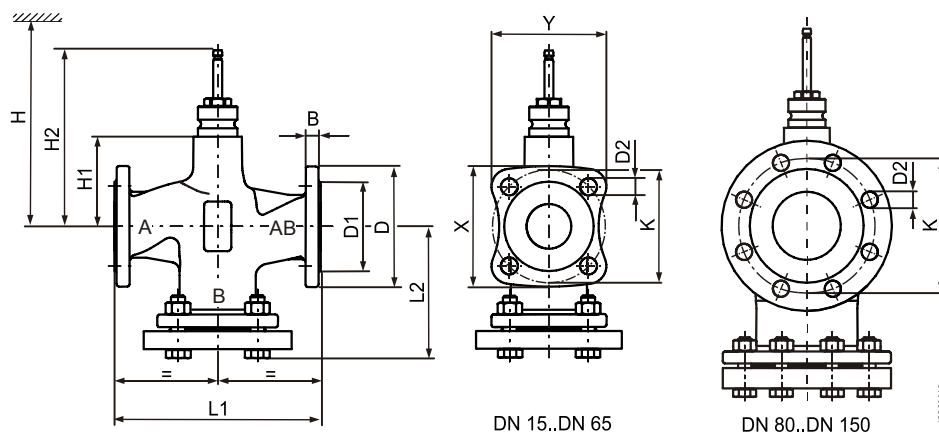

Product number	DN	kg	B	Ø D	Ø D1	Ø D2	L1	L2	X	Y	Ø K	H1	H2	H				
														SAX..	SKD..	SKB..	SAV..	SKC..
VVF42..	15	3.7	14	95	46	14 (4x)	130	86	79	76	65	37	133.5	479	537	612	-	-
	20	4.7	16	105	56	14 (4x)	150	97	86.6	83	75	37	133.5	479	537	612	-	-
	25	5.4	15	115	65	14 (4x)	160	106.5	94.4	90.1	85	37	133.5	479	537	612	-	-
	32	8.4	17	140	76	19 (4x)	180	119	115.6	110.7	100	37	133.5	479	537	612	-	-
	40	9.3	16	150	84	19 (4x)	200	126	123.2	117.8	110	37	133.5	479	537	612	502	-
	50	12.2	16	165	99	19 (4x)	230	144	135.2	128.4	125	50	146.5	492	550	625	525	-
	65	17	17	185	118	19 (4x)	290	174	150	142.5	145	75	171.5	517	575	650	540	-
	80	25	17	200	132	19 (8x)	310	186	-	-	160	75	171.5	517	575	650	540	-
	100	35.9	17	220	156	19 (8x)	350	205	-	-	180	110	226.5	-	-	-	575	685
	125	52.5	17	250	184	19 (8x)	400	233	-	-	210	123	239.5	-	-	-	588	698
150	74.9	17	284	211	23 (8x)	480	275.5	-	-	240	150.5	267	-	-	-	616	726	
VVF42..K	50	12	16	165	99	19 (4x)	230	144	135.2	128.4	125	50	146.5	492	550	625	-	-
	65	17.5	17	185	118	19 (4x)	290	174	150	142.5	145	75	171.5	517	575	650	-	-
	80	27	17	200	132	19 (8x)	310	186	-	-	160	75	171.5	517	575	650	-	-
	100	35.9	17	220	156	19 (8x)	350	206	-	-	180	110	226.5	-	-	-	575	685
	125	52.3	17	250	184	19 (8x)	400	233	-	-	210	123	239.5	-	-	-	588	698
150	76.3	17	284	211	23 (8x)	480	275.5	-	-	240	150.5	267	-	-	-	616	726	

VXF42..

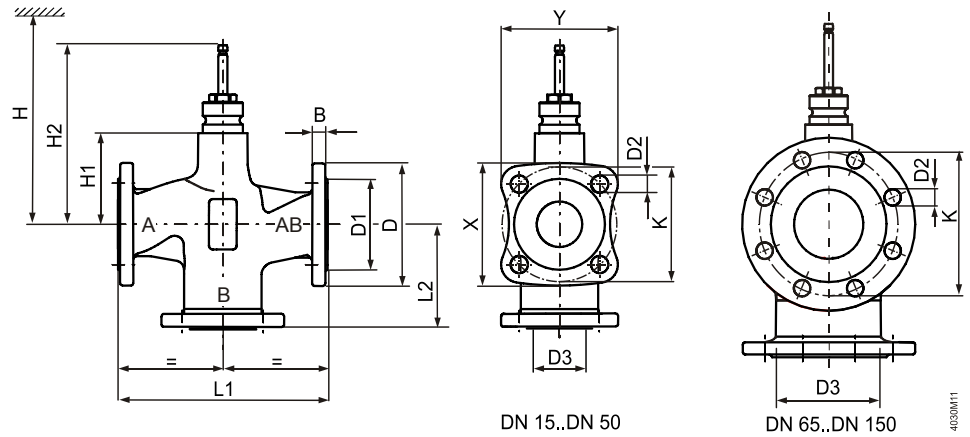

Product number	DN	kg	B	Ø D	Ø D1	Ø D2	Ø D3	L1	L2	X	Y	Ø K	H1	H2	H				
															SAX..	SKD..	SKB..	SAV..	SKC..
VXF42..	15	2.6	14	95	46	14 (4x)	23	130	65	79	76	65	37	133.5	479	537	612	-	-
	20	3.3	16	105	56	14 (4x)	29	150	75	86.6	83	75	37	133.5	479	537	612	-	-
	25	3.8	15	115	65	14 (4x)	36	160	80	94.4	90.1	85	37	133.5	479	537	612	-	-
	32	5.7	17	140	76	19 (4x)	46	180	90	115.6	110.7	100	37	133.5	479	537	612	-	-
	40	6.3	16	150	84	19 (4x)	56	200	100	123.2	117.8	110	37	133.5	479	537	612	502	-
	50	8.7	16	165	99	19 (4x)	69	230	115	135.2	128.4	125	50	146.5	492	550	625	525	-
	65	12.9	17	185	118	19 (4x)	85	290	145	150	142.5	145	75	171.5	517	575	650	540	-
	80	19.2	17	200	132	19 (8x)	102	310	155	-	-	160	75	171.5	517	575	650	540	-
	100	29	17	220	156	19 (8x)	124	350	175	-	-	180	110	226.5	-	-	-	575	685
	125	43.2	17	250	184	19 (8x)	149	400	200	-	-	210	123	239.5	-	-	-	588	698
150	62.1	17	284	211	23 (8x)	174	480	240	-	-	240	150.5	267	-	-	-	616	726	

Spare parts

Stem sealing gland

Product number	DN	Stock number	Comments	Image
VVF42.. VXF42..	DN 15...80	4 284 8806 0	Series A	
	DN 100...150	4 284 8806 0	Series A, B and C until October 2015	
	DN 100...150	4 679 5629 0	Series D as of October 2015	
VVF42..K	DN 50...150	4 284 8806 0	Serie A	

Revision numbers

VVF..
VXF..

Product number	Valid from rev. no.	Product number	Valid from rev. no.
VVF42.15-1.6	..A	VXF42.15-1.6	..A
VVF42.15-2.5	..A	VXF42.15-2.5	..A
VVF42.15-4	..A	VXF42.15-4	..A
VVF42.20-6.3	..A	VXF42.20-6.3	..A
VVF42.25-6.3	..A	VXF42.25-6.3	..A
VVF42.25-10	..A	VXF42.25-10	..A
VVF42.32-16	..A	VXF42.32-16	..A
VVF42.40-16	..A	VXF42.40-16	..A
VVF42.40-25	..A	VXF42.40-25	..A
VVF42.50-31.5	..A	VXF42.50-31.5	..A
VVF42.50-40	..A	VXF42.50-40	..A
VVF42.65-50	..A	VXF42.65-50	..A
VVF42.65-63	..A	VXF42.65-63	..A
VVF42.80-80	..A	VXF42.80-80	..A
VVF42.80-100	..A	VXF42.80-100	..A
VVF42.100-125	..D	VXF42.100-125	..D
VVF42.100-160	..D	VXF42.100-160	..D
VVF42.125-200	..D	VXF42.125-200	..D
VVF42.125-250	..D	VXF42.125-250	..D
VVF42.150-300	..D	VXF42.150-300	..D
VVF42.150-400	..D	VXF42.150-400	..D
VVF42.50-40K	..A		
VVF42.65-63K	..A		
VVF42.80-100K	..A		
VVF42.100-160K	..A		
VVF42.125-250K	..A		
VVF42.150-360K	..A		

Issued by
Siemens Switzerland Ltd
Building Technologies Division
International Headquarters
Gubelstrasse 22
6301 Zug
Switzerland
Tel. +41 41-724 24 24
www.siemens.com/buildingtechnologies

© Siemens Switzerland Ltd, 2013
Technical specifications and availability subject to change without notice.